



ESX, TSXA, TSX ELLIPTICAL OWNER'S MANUAL





Frank Trulaske, founder and CEO of TRUE®, has had the same simple philosophy of delivering superior products, service and support for over 29 years. Today, TRUE is the global leader in premium cardio equipment for the commercial and residential markets. Our goal is to be the leader in technology, innovation, performance, safety and style. TRUE has received many awards for its commercial and retail product over the years and remains the benchmark for the industry. Fitness facilities and consumers invest in TRUE products for their durable commercial platforms used in all its cardio products, commercial, light commercial and residential alike.

The proud manufacturing traditions of quality and the culture of innovation at TRUE has given rise to a full line of truly extraordinary treadmills, indoor cycles and elliptical cross-trainers. As a result, people all over the world are benefiting from the TRUE experience. Innovation across the full product line has made TRUE successful and is a trademark of the TRUE heritage. TRUE's patented Heart Rate Control® technology is just one of the remarkable ways we deliver simple and superior performance every user can enjoy, and most importantly, use to achieve personal health and fitness goals.

TRUE strives to perfect biomechanically correct and orthopedically comfortable, functional products. Whether it be the mesh seat in the recumbent bike, the Soft Step® in the elliptical cross-trainers or the Soft System® in our treadmills, we deliver the best.

At the heart of our success is the relentless and systematic life testing of both our products and their components. We have dedicated employees who understand our philosophy is to deliver the best products in the world.

Our goal is not to sell the most cardio products in the world, but to deliver the world's best premium equipment for our customers' health and fitness solutions.

To own a TRUE machine is to be part of an exclusive fitness community that delivers results – your results.

Thank you for becoming a part of the TRUE experience.

TABLE OF CONTENTS

| | |
|---|----|
| Chapter 1: Safety Instructions..... | 4 |
| Chapter 2: Elliptical Overview..... | 10 |
| Chapter 3: Display Console..... | 14 |
| Chapter 4: Programming & Operation..... | 17 |
| Chapter 5: Care & Maintenance..... | 22 |
| Chapter 6: Troubleshooting..... | 24 |
| Chapter 7: Additional Information..... | 26 |

IMPORTANT:

Product specifications, features & software are subject to change without notice.

CHAPTER 1: SAFETY INSTRUCTIONS



Chapter 5: Care & Maintenance

Chapter 6: Troubleshooting

Chapter 7: Additional Information

IMPORTANT SAFETY INSTRUCTIONS SAVE THESE SAFETY INSTRUCTIONS

CAUTION: Health related injuries may result from incorrect or excessive use of exercise equipment.

TRUE STRONGLY recommends seeing a physician for a complete medical exam before undertaking an exercise program, particularly if the user has a family history of high blood pressure or heart disease, is over the age of 45, smokes, has high cholesterol, is obese or has not exercised regularly in the past year. TRUE also recommends consulting a fitness professional on the correct use of this product. If at any time while exercising the user experiences faintness, dizziness, pain or shortness of breath, he or she must stop immediately.

GETTING STARTED

WARNING: READ ALL INSTRUCTIONS BEFORE USING THE ELLIPTICAL.

WARNING: To reduce the risk of electrical shock, always unplug this TRUE product before cleaning or attempting any maintenance activity.

WARNING: To reduce the risk of burns, fire, electric shock or injury, it is imperative to connect each product to a properly grounded electrical outlet. A risk of electrical shock may result from improper connection of the equipment's grounding conductor. Check with a qualified electrician if you are unsure about proper grounding techniques. Do not modify the plug provided with this product. If it will not fit an electrical outlet, have a proper outlet installed by a qualified electrician. Your TRUE Fitness product must be properly grounded to reduce risk of shock if the elliptical malfunctions. Your elliptical is equipped with an electrical cord, which includes an equipment grounding conductor and a grounding plug. The plug must be inserted into an outlet that has been properly installed and grounded in accordance with all local codes and ordinances. A temporary adapter cannot be used to connect this plug to a two-pole receptacle in North America. If a properly grounded 15 amp outlet is not available, a qualified electrician must install one.

WARNING: Keep instructions out of reach of children.

WARNING: Do not move the elliptical by lifting the console. Do not use the console as a handlebar during a workout.

IMPORTANT SAFETY INSTRUCTIONS:

- When using this exercise machine, basic precautions should always be followed, including the following:
- This appliance [ES 120V (models ESX, TSXa, TSX)] is intended for residential use.
- Read all instructions before using this treadmill.

DANGER: To reduce the risk of electric shock, always unplug the elliptical before cleaning.

WARNING: To reduce the risk of burns, fire and electric shock or injury to persons, follow these instructions:

- This appliance should never be left unattended when plugged in.
- Unplug it from the outlet when not in use and before any servicing.
- Do not operate the elliptical while being covered with a blanket, plastic, or anything that insulates or stops airflow.
- Close supervision is necessary if the elliptical is used by children, used near children. Also applies to disabled persons.
- Use this elliptical only for its intended use as described in this manual.
- Do not use attachments not recommended by the manufacturer.
- Never operate this elliptical if it has a damaged power cord or plug, if it is not working properly, if it has been damaged or dropped, or if it has been submerged in water. In these cases, a qualified service technician should examine this elliptical.
- Do not use the power cord as a handle for transporting.
- Keep the power cord away from heated surfaces.
- Never operate the with the air vents blocked. Keep air vents free from clogs.
- Never drop or insert any object into any opening.
- Use indoors only.
- Do not operate where aerosol (spray) products are being used or where oxygen is being administered.
- To disconnect power cord, first turn power switch to the off position, then remove plug from outlet.
- Allow only trained personnel to service this equipment.

IMPORTANT SAFETY INSTRUCTIONS:

- Never use near water or while wet. Using this elliptical around a pool, hot tub or sauna will void the warranty.
- Avoid the possibility of bystanders being struck or caught between moving parts by making sure that they are out of reach of the elliptical while it is in motion.
- Allow only one person at a time on the elliptical while it's operating.
- Ensure that the back of the elliptical is placed at least 39" away from a wall or other obstructions.
- Ensure that the sides of the elliptical are placed at least 20" away from a wall or other obstructions.
- Do not allow animals on or near the elliptical while it's operating.
- Consult your physician before beginning any exercise program.
- Do not use if you have a cold or fever.

GROUNDING INSTRUCTIONS

- This product must be grounded. If it should malfunction or breakdown, grounding provides a path of least resistance for electric current to reduce the risk of electric shock. This product is equipped with a cord having an equipment-grounding conductor and a grounding plug. The plug must be plugged into an appropriate outlet that is properly installed and grounded in accordance with all local codes and ordinances.

DANGER: Improper connection of the equipment-grounding conductor can result in a risk of electric shock. Check with a qualified electrician or serviceman if you are in doubt as to whether the product is properly grounded. Do not modify the plug provided with the product – if it will not fit the outlet; have a proper outlet installed by a qualified electrician.

- The 120-V model is for use on a nominal 120-V circuit and has a grounding plug that looks like the plug illustrated in figure A. Make sure the product is connected to an outlet having the same configuration as the plug. No adaptor should be used with this product.
- The 230-V model is for use on a circuit having a nominal rating more than 120-V and is factory-equipped with a specific electric cord and has a grounding plug that looks like the plug illustrated in figure B. Make sure that the product is connected to an outlet having the same configuration as the plug in Figure B. No adapter should be used with this product. If the product must be reconnected for use on a different type of electric circuit, the reconnection should be made by qualified service personnel.

GROUNDING INSTRUCTIONS

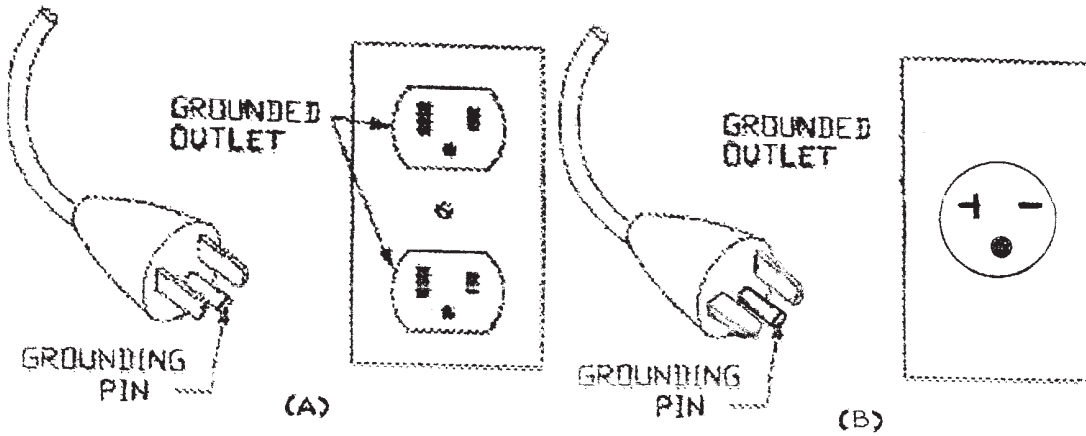

CAUTION:

- To avoid injury stand on the side rails before starting the elliptical.
- To disconnect, turn power OFF at the ON/OFF switch, then remove plug from electrical outlet.
- Never operate a TRUE product if it has a damaged power cord or electrical plug, or if it has been dropped, damaged, or even partially immersed in water. Contact TRUE Customer Service.
- Position this product so the power cord plug is accessible to the user.
- Keep the power cord away from heated surfaces. Do not pull the equipment by the power cord or use the cord as a handle. Do not run the power cord along the side or under the elliptical.
- If the electrical supply cord is damaged it must be replaced by the manufacturer, an authorized service agent, or a similarly qualified person to avoid a hazard.
- Do not use this product in areas where aerosol spray products are being used or where oxygen is being administered. Such substances create the danger of combustion and explosion.
- Always follow the console instructions for proper operation. Close supervision is necessary when used by or near children, or disabled persons.
- Do not use this product outdoors, near swimming pools or in areas of high humidity including extreme temperature changes
- Never operate a TRUE product with the air openings blocked. Keep air openings free of lint, hair or any obstructing material.
- Never insert objects into any openings in this product. If an object should drop inside, turn off the power, unplug the power cord from the outlet and carefully retrieve it. If the item cannot be reached, contact TRUE Customer Service.
- Never place liquids of any type directly on the unit except in the accessory tray or bottle holders. Containers with lids are recommended.
- Wear shoes with rubber or high traction soles. Do not use shoes with heels, leather soles, cleats or spikes. Make sure no stones are embedded in the soles. Do not use this product in bare feet. Keep all loose clothing, shoelaces and towels away from moving parts.
- Do not reach into or underneath the unit, or tip it on its side during operation.
- Keep rear of the elliptical at least 39" away from the wall or other obstructions and the sides of the elliptical at least 20" away from the wall or obstructions.
- Use the side handrails whenever additional stability is required. In case of emergency, such as tripping, the side handrails should be grabbed and the user should place his/her feet on the side platforms. The front handlebars should be used to grasp the heart rate sensors or to rest the hand on while operating the activity zone keys, but not for stability, emergency, or continuous use.
- Do not exceed maximum user weight as outlined in the product specification section of this manual.

CHAPTER 2: ELLIPTICAL OVERVIEW



Chapter 1: Basic Safety

Chapter 2: Elliptical Overview

Chapter 3: Display Console

Chapter 4: Programming & Operation

Chapter 5: Care & Maintenance

Chapter 6: Troubleshooting

Chapter 7: Additional Information

ESX



TSXA

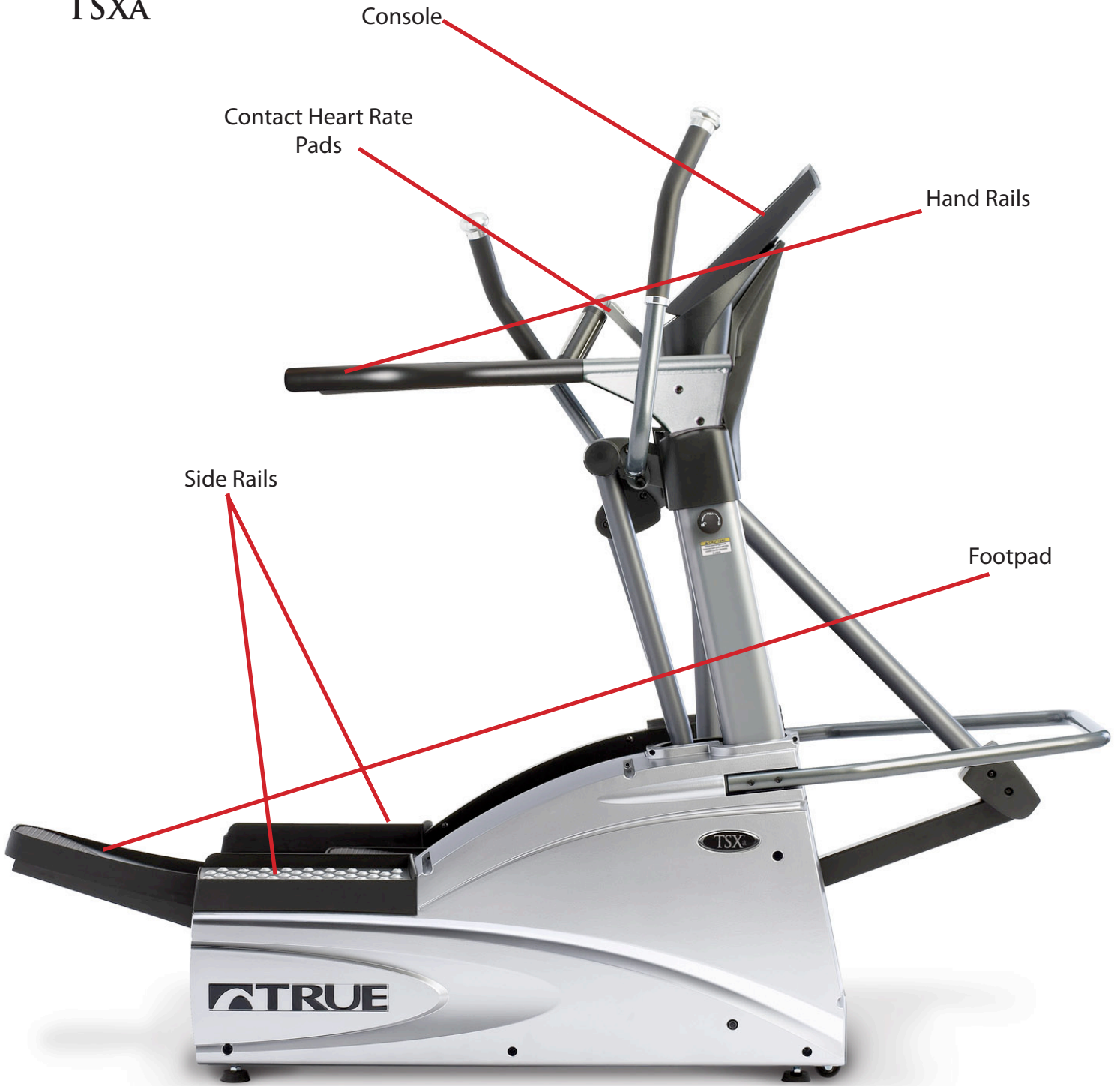

TSX



CHAPTER 3: DISPLAY CONSOLE



Chapter 1: Safety Instructions

Chapter 2: Elliptical Overview

Chapter 3: Display Console

Chapter 4: Programming & Operation

Chapter 5: Care & Maintenance

Chapter 6: Troubleshooting

Chapter 7: Additional Information

ESX, TSXA

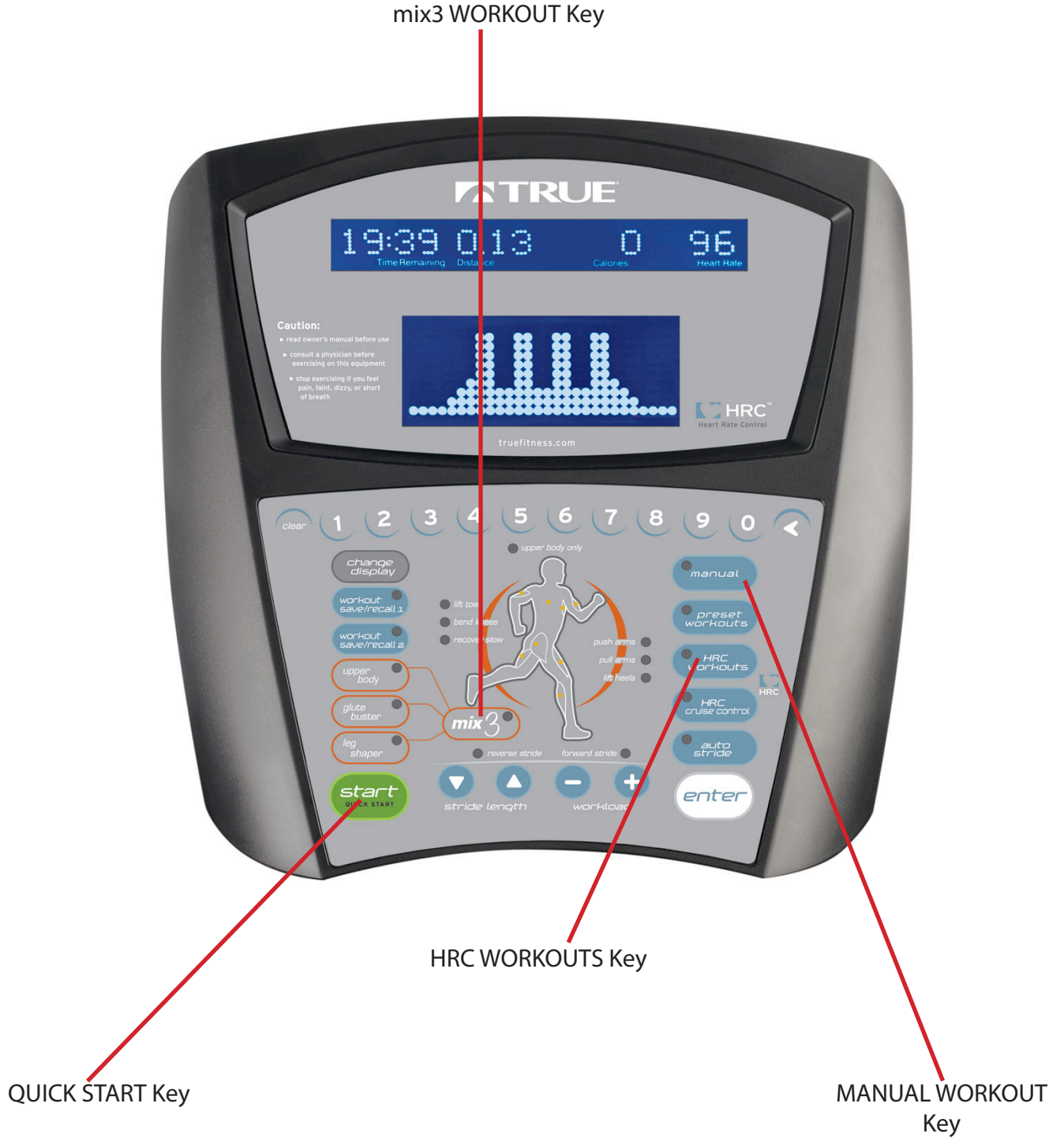

TSX



QUICK START Key

mix3 WORKOUT Key

HRC WORKOUTS Key

MANUAL WORKOUT Key

CHAPTER 4: PROGRAMMING & OPERATION



| |
|---|
| Chapter 1: Safety Instructions |
| Chapter 2: Elliptical Overview |
| Chapter 3: Display Console |
| Chapter 4: Programming & Operation |
| Chapter 5: Care & Maintenance |
| Chapter 6: Troubleshooting |
| Chapter 7: Additional Information |

Here is a list of programming options available on your elliptical. Operation may differ depending on the model. For more information on programming and operation please visit www.truefitness.com.

mix3:

- mix3: is a cross-training workout that gives you the most exercise for your training time, both lower-body and upper-body. The program takes you through a sequence of exercises that is slightly different each time. The duration of each exercise varies between 30, 40, 50, or 60 seconds.

Preset Workouts:

- Rolling Hills: a series of gently changing workloads
- One Big Hill: with the workload gradually increasing to a maximum at the halfway point, then decreasing gradually to the end.
- Easy Intervals: with a moderate change between work and rest intervals.
- Sport Intervals: with a large change between work and rest intervals.

Manual Workout: This is a workout where all aspects of the workout (workout time, distance, workload and level) are decided by the user.

TARGET HEART RATE

TRUE's heart rate control (HRC) workouts let the elliptical monitor your relative exercise intensity by way of your heart rate, then automatically adjust the workload to keep you at your target heart rate and thus your desired exercise intensity.

Your heart rate is a good measure of your body's exercise stress level. It reflects differences in your physical condition, how tired you are, the comfort of the workout environment, even your diet and emotional state. Using heart rate to control workload takes the guesswork out of your workout settings.

Consult your physician before using heart rate controlled workouts for advice on selecting a target heart rate range. Also, it is important to use the elliptical for several workouts in the manual mode while monitoring your heart rate.

Compare your heart rate with how you feel to ensure your safety and comfort.

You need to wear a heart rate monitoring chest strap to use heart rate control. Monitoring is not recommended when using the contact heart rate system for heart rate control workouts.

INSTRUCTIONS:

Put on a Polar® or compatible transmitter chest strap.

Press ENTER until you reach desired program.

Enter your target heart rate using numeric keys or + and – keys and press ENTER

Adjust time using numeric keys or + and – keys and press ENTER

Enter maximum speed and press ENTER

Enter maximum grade and press ENTER

Press START to begin program

WARM UP:

At the beginning of an HRC workout, the elliptical is in full Manual Control mode. Gradually increase your work level to slowly raise your heart rate to within 10 beats per minute (bpm) of your target heart rate.

AT THE HEART RATE CONTROL STAGE the elliptical takes control of workload and resistance keeping your heart rate within a few bpm of your target. If you are using interval HRC, the elliptical alternates between work and rest intervals.

COOL-DOWN:

At the end of your workout time or distance, the elliptical reduces workload by half and goes back into Manual Control mode, where you directly control your cool-down.

Your elliptical can remember more than one workout setup for a heart rate control workout. You can select these in later workouts so you don't have to re-enter your workout parameters, which tend to stay the same from workout to workout.

During workout setup, if you keep pressing ENTER you will continue to scroll through the workout setup parameters. You can press ENTER at any time to accept the current parameters and begin your workout.

HEART RATE CRUISE CONTROL

While in any workout, set your current heart rate as your target heart rate by pressing the HRC CRUISE CONTROL key.

USER DEFINED WORKOUTS/SETTINGS:

HEART RATE MONITORING:

This treadmill can monitor your heart rate using either the chest strap provided with the treadmill or the metal grips on the hand rails (called contact heart rate or CHR pads). A chest strap transmits your heart rate to the treadmill via radio, and the CHR pads connect to a special computer circuit to extract your heart rate.

CHEST STRAP HEART RATE MONITORING:

Although this treadmill functions fine without using the heart rate monitoring feature, this kind of monitoring gives you valuable feedback on your effort level. Chest strap monitoring also allows you to use Heart Rate Control, the most advanced exercise control system available.

When you wear a Polar® or compatible transmitter strap, the treadmill will display your heart rate as a digital beats-per-minute (bpm) readout.

The transmitter strap should be worn directly against your skin, about one inch below the pectoral muscles/breast line (see picture). Women should be careful to place the transmitter below their bra line.

Some moisture is necessary between the strap and your skin. Sweat from your exercise works best, but ordinary tap water may be used prior to your workout if desired.



A NOTE ON HEART RATE MONITORING:

The chest strap produces a FM signal that the treadmill reads and registers your heart rate. The accuracy of a reading may be affected when outside interference is present.

CONTACT HEART RATE (CHR):

The CHR system lets you monitor your heart rate without wearing a strap.

Gently grasp the CHR pads.

During this time, the system is analyzing and locking in your heart rate.

Within about 15 seconds, your digital heart rate in beats per minute (bpm) should be displayed.

IMPORTANT:

Exercise with smooth body motions.

Breathe smoothly and regularly, and avoid talking.

(Talking will cause unrepresentative heart rate spikes of 5 to 10 bpm.)

Grip the pads lightly, not tightly.

Make sure your hands are clean, free of both dirt and hand lotions.

When using a HRC workout, it is best to use chest strap monitoring.

Heart rate based workouts work best with the extra accuracy gained from a chest strap heart rate monitoring system.

A NOTE ON CHR ACCURACY:

CHR monitoring may be less accurate than a chest strap, since the heart rate signals are much stronger at the chest.

CHAPTER 5: CARE & MAINTENANCE



Chapter 1: Safety Instructions

Chapter 2: Elliptical Overview

Chapter 3: Display Console

Chapter 4: Programming & Operation

Chapter 5: Care & Maintenance

Chapter 6: Troubleshooting

Chapter 7: Additional Information

CARE & MAINTENANCE

It is important to perform the minor maintenance tasks described in this section. Failure to maintain the elliptical as described here could void the TRUE Fitness Warranty. To reduce the risk of electrical shock, always unplug the unit from its power source before cleaning or performing any maintenance tasks.

INSPECTION:

Inspect the elliptical daily. Look and listen for loose fasteners, unusual noises, worn or frayed power cords, and any other indications that the equipment may be in need of service. If you notice any of these, obtain service.

IMPORTANT: If you determine that the elliptical needs service, make sure that the elliptical cannot be used inadvertently. Turn the unit Off, and then unplug the power cord from its power source. Remove the magnetic safety key and safety clip and store it in a safe place. Make sure other users know that the elliptical needs service.

CLEANING THE EQUIPMENT:

TRUE recommends the elliptical be cleaned before and after each workout. Use mild soap and water to dampen a soft cloth and wipe all exposed surfaces. This helps remove any dust or dirt.

CAUTION: Do not use any acidic cleaners. Doing so will weaken the paint or powder coatings and may void the TRUE Fitness Warranty. Never pour water or spray liquids on any part of the elliptical. Allow the elliptical to dry completely before using. Frequently vacuum the floor underneath the unit to prevent the accumulation of dust and dirt, which can affect the smooth operation of the unit.

STORING THE CHEST STRAP:

Store the chest strap in a place where it remains free of dust and dirt such as, in a closet or drawer. Be sure to protect the chest strap from extremes in temperature. Do not store it in a place that may be exposed to temperatures below 32° F (0° C). To clean the chest strap, use a sponge or soft cloth dampened in mild soap and water. Dry the surface thoroughly with a clean towel.

LONG TERM STORAGE:

When the treadmill is not in use for any length of time, turn it off. Make sure that the power cord is unplugged from the power source and is positioned so that it will not become damaged or interfere with people or other equipment.

CHAPTER 6: TROUBLESHOOTING



| |
|------------------------------------|
| Chapter 1: Safety Instructions |
| Chapter 2: Elliptical Overview |
| Chapter 3: Display Console |
| Chapter 4: Programming & Operation |
| Chapter 5: Care & Maintenance |
| Chapter 6: Troubleshooting |
| Chapter 7: Additional Information |

BASIC TREADMILL TROUBLESHOOTING GUIDE

The following are common questions that are asked. For all other inquiries we would ask that you call your local dealer/service provider in your area for support.

Q. What does it mean when my panel displays no lights?

A. Such symptoms can be caused by:

- Verify you are receiving power to your outlet by using an alternative device.
- It could mean that your unit is not plugged in.
- You will need to check the toggle switch on the front base of the unit to make sure it is in the ON position.
- You can check to see if your circuit breaker switch on your unit has been tripped. If so, you can reset it and the lights should reappear on your display. If it will not reset, you will need to call your local dealer or service provider to set up a service call.

Q. The upper display shows an error code or has odd characters.

A. If your display has any error messages on it TRUE Fitness recommends that you contact your local dealer or service provider to arrange a service call. The error codes are there for your protection and we do not recommend that you continue using the unit without consulting a professional.

Q. Is there any maintenance that I need to do to my elliptical?

A. TRUE Fitness encourages our customers to set themselves up with a preventative maintenance contract. These can be provided through your dealer or local service provider.

Q. How do I arrange for a service or preventative maintenance appointment?

A. TRUE Fitness recommends that you gather the serial number, model number, and a brief description of the reason for the request before contacting anyone. Once that information has been gathered you may contact your selling dealer or local service company to set an appointment. (If you are not familiar with who is in your area, you may visit our website at www.truefitness.com and use our dealer locator to obtain the contact information for the closest dealer in your area.)

If you would like you may also contact TRUE Fitness' customer support team by calling 800.883.8783 or e-mailing us at info@truefitness.com Monday – Friday during normal business hours with any further questions or comments.

CHAPTER 7: ADDITIONAL INFORMATION



| |
|---|
| Chapter 1: Safety Instructions |
| Chapter 2: Elliptical Overview |
| Chapter 3: Display Console |
| Chapter 4: Programming & Operation |
| Chapter 5: Care & Maintenance |
| Chapter 6: Troubleshooting |
| <i>Chapter 7: Additional Information</i> |

ESX

| | | |
|--|------------------------------------|---|
| DRIVE SYSTEM | Power Source | Plug-In |
| | Drive System | Core Drive |
| | Resistance Source | Eddy Current Brake |
| EXERCISE SURFACE | Stride Length | Electronic Adjustment 17" - 26" (43cm - 66cm) |
| | Auto Stride | YES |
| | Pedal Spacing | 2" (5 cm) |
| | Footpad Material | Orthopedic Soft Step Cushioned Anti-Fatigue Material (Removable for Easy Cleaning) |
| FRAME | Frame | Robotically Welded Steel |
| | Handrails/Handlebars | Extended Handrails for Easy Entry and Exit |
| | Upper-Body/Arms | Ergonomically Designed / Upper-Body Only Capability |
| | Fixed Side Steps | Innovative Patent-Pending Side Steps Provide Upper-Body Only Workout Option |
| | Personalized Handle Bar Adjustment | 5 Settings |
| | Ergonomic Rotating Handle | 360 Degree Rotation |
| | Console | Display Type |
| CONSOLE | Key Type | Membrane |
| | Express Command Keys | YES |
| | Data Readouts | Elapsed Time, Time Remaining, Distance, RPM, Heart Rate, Work Level, Target Heart Rate, Watts, METs, Calories |
| | Pause Feature | 30 Minute Pause |
| | Sleep Mode | YES |
| | HEART RATE | Contact Heart Rate Monitoring |
| Wireless Heart Rate Monitoring | | YES |
| Heart Rate Monitoring Chest Strap Included | | YES |
| HRC (Heart Rate Control)® Workouts | | 1 - Target |
| HRC Cruise Control™ | | YES |
| PROGRAMMING | Programs | 9 Preset |
| | Manual Workout Resistance Levels | 25 |
| | Workout Setup Memory Keys | YES - 2 |
| OTHER FEATURES | Accessories | Reading Rack and 2 Water Bottle Holders |
| | Safety | TRUE Lock™, Handrails for Easy Entry and Exit, Side Step-Up Areas and Low Step-Up Height |
| PHYSICAL SPECIFICATIONS | Footprint | 65.5"L x 31.5"W x 62.5"H (166 cm x 81 cm x 160 cm) |
| | Active Footprint | 77.5"L x 31.5"W x 62.5"H (190 cm x 81 cm x 160 cm) |
| | Machine Weight | 326 lbs (148 kg) |
| | Maximum User Weight | 350 lbs (159 kg) |
| | Workload Range | 25 - 300 Watts |
| | Breakdown Capability | Able to Fit Through Doorways as Small as 24" |
| | Transport Wheels | YES |
| | Transport Handles | YES |
| WARRANTY | Warranty | Frame Lifetime, Parts 10 Years, Labor 1 Year |

TSX_a

| | | |
|-------------------------|--|---|
| DRIVE SYSTEM | Power Source | Plug-In |
| | Drive System | Core Drive |
| | Resistance Source | Eddy Current Brake |
| EXERCISE SURFACE | Stride Length | Electronic Adjustment 17" - 26" (43cm - 66cm) |
| | Auto Stride | YES |
| | Pedal Spacing | 2" (5 cm) |
| | Footpad Material | Orthopedic Soft Step Cushioned Anti-Fatigue Material (Removable for Easy Cleaning) |
| FRAME | Frame | Robotically Welded Steel |
| | Handrails/Handlebars | Extended Handrails for Easy Entry and Exit |
| | Upper-Body/Arms | Ergonomically Designed / Upper-Body Only Capability |
| | Fixed Side Steps | Innovative Patent-Pending Side Steps Provide Upper-Body Only Workout Option |
| | Personalized Handle Bar Adjustment | N/A |
| | Ergonomic Rotating Handle | N/A |
| CONSOLE | Display Type | Dual Window Custom LCD |
| | Key Type | Membrane |
| | Express Command Keys | YES |
| | Data Readouts | Elapsed Time, Time Remaining, Distance, RPM, Heart Rate, Work Level, Target Heart Rate, Watts, METs, Calories |
| | Pause Feature | 30 Minute Pause |
| | Sleep Mode | YES |
| HEART RATE | Contact Heart Rate Monitoring | YES |
| | Wireless Heart Rate Monitoring | YES |
| | Heart Rate Monitoring Chest Strap Included | YES |
| | HRC (Heart Rate Control) [®] Workouts | 1 - Target |
| | HRC Cruise Control [™] | YES |
| PROGRAMMING | Programs | 9 Preset |
| | Manual Workout Resistance Levels | 25 |
| | Workout Setup Memory Keys | YES - 2 |
| OTHER FEATURES | Accessories | Reading Rack and 2 Water Bottle Holders |
| | Safety | TRUE Lock [™] , Handrails for Easy Entry and Exit, Side Step-Up Areas and Low Step-Up Height |
| PHYSICAL SPECIFICATIONS | Footprint | 65.5"L x 31.5"W x 62.5"H (166 cm x 81 cm x 160 cm) |
| | Active Footprint | 77.5"L x 31.5"W x 62.5"H (190 cm x 81 cm x 160 cm) |
| | Machine Weight | 325 lbs (148 kg) |
| | Maximum User Weight | 350 lbs (159 kg) |
| | Workload Range | 25 - 300 Watts |
| | Breakdown Capability | Able to Fit Through Doorways as Small as 24" |
| | Transport Wheels | YES |
| | Transport Handles | YES |
| WARRANTY | Warranty | Frame Lifetime, Parts 5 Years, Labor 1 Year |



The TRUE® TSX™ elliptical incorporates TRUE's patented Core Drive™ system to deliver the most comfortable, natural and stable workout in the industry. The innovative side-steps not only allow for safe entry and exit from the machine but also unparalleled versatility by providing the industry's first upper-body only workout.

PREMIUM FEATURES:

- **SMALL FOOTPRINT TO MAXIMIZE YOUR WORKOUT SPACE:** Unlike other ellipticals, the TRUE TSX provides a space efficient approach to home exercise. Now you can do more with your workout space.
- **SAFE AND COMFORTABLE:** During exercise, users will notice the exceptional comfort of TRUE's Soft Step® orthopedic footpads which decrease the stress of impact on joints and can eliminate foot numbness associated with many traditional ellipticals.
- **EFFECTIVE AND INSPIRING:** Implement variety into your workout by using TRUE's mix3™ program. It's our version of the personal trainer to coach you through a total-body workout that will shape and tone every major muscle group. The blue LCD screen and aluminum handle accents are stylish touches to this powerful machine.
- **MADE WITH YOU IN MIND:** Biomechanically engineered handle positioning provides the highest standard of comfort during your workout.
- **MADE TO GO THE DISTANCE:** The TRUE TSX is manufactured with commercial-grade materials and the finest components for extreme durability. Coupled with a great warranty and service plan, you know that your TSX elliptical will stand up to years of heavy use.

| | | |
|------------------|------------------------------------|--|
| DRIVE SYSTEM | Power Source | Plug-In |
| | Drive System | Core Drive |
| | Resistance Source | Eddy Current Brake |
| EXERCISE SURFACE | Stride Length | Fixed - 21" (53 cm) |
| | Auto Stride | N/A |
| | Pedal Spacing | 2" (5 cm) |
| | Footpad Material | Orthopedic Soft Step Cushioned Anti-Fatigue Material (Removable for Easy Cleaning) |
| FRAME | Frame | Robotically Welded Steel |
| | Handrails/Handlebars | Extended Handrails for Easy Entry and Exit |
| | Upper-Body/Arms | Ergonomically Designed / Upper-Body Only Capability |
| | Fixed Side Steps | Innovative Patent-Pending Side Steps Provide Upper-Body Only Workout Option |
| | Personalized Handle Bar Adjustment | N/A |
| | Ergonomic Rotating Handle | N/A |
| CONSOLE | Display Type | Dual Window Custom LCD |
| | Key Type | Membrane |
| | Express Command Keys | YES |
| | Data Readouts | Time, Distance, RPM, Heart Rate, Work Level, Watts, METs, Calories |
| | Pause Feature | 30 Minute Pause |
| | Sleep Mode | YES |

| | | |
|-------------------------|--|---|
| HEART RATE | Contact Heart Rate Monitoring | YES |
| | Wireless Heart Rate Monitoring | YES |
| | Heart Rate Monitoring Chest Strap Included | YES |
| | HRC (Heart Rate Control)® Workouts | 1 - Target |
| | HRC Cruise Control™ | YES |
| PROGRAMMING | Programs | 9 Preset |
| | Manual Workout Resistance Levels | 25 |
| | Workout Setup Memory Keys | N/A |
| OTHER FEATURES | Accessories | Reading Rack and 2 Water Bottle Holders |
| | Safety | Extended Handrails for Easy Entry and Exit, Side Step-Up Areas and Low Step-Up Height |
| PHYSICAL SPECIFICATIONS | Footprint | 62"L x 31.5"W x 62.5"H (152 cm x 81 cm x 160 cm) |
| | Active Footprint | 72"L x 31.5"W x 62.5"H (178 cm x 81 cm x 160 cm) |
| | Machine Weight | 311 lbs (141 kg) |
| | Maximum User Weight | 350 lbs (159 kg) |
| | Workload Range | 25 - 300 Watts |
| | Breakdown Capability | Able to Fit Through Doorways as Small as 24" |
| | Transport Wheels | YES |
| Transport Handles | YES | |
| WARRANTY | Warranty | Frame Lifetime, Parts 5 Years, Labor 1 Year |

ESX Warranty

Save time and register online!
 Activate Multiple Warranties at truefitness.com.

All TRUE® Fitness products are distributed by TRUE and are warranted to the original registered Product purchaser and the parts of the TRUE product (the "Product") listed below, under normal use and service, shall be free of manufacturing defects in workmanship and materials only for the period of time beginning from the original date of purchase set forth below:

| | |
|---------------------|-----------------|
| Frame* | Lifetime |
| Parts | |
| Electrical | 10 Years |
| Wear Items | 10 Years |
| Cosmetics | 6 Months |
| Touch Screen | 5 Years |
| Labor | |
| Parts | 1 Year |
| Cosmetics | 6 Months |

NOTE: Warranty valid for USA and Canada only.

Frame

The frame is warranted for defects in material and workmanship for as long as the original purchaser owns the Product. The frame is warranted for labor and freight (for part shipped from TRUE) for one year from date of purchase. *This limited warranty on structural frame does not include paint or coatings.

Parts

The elliptical electrical parts and wear items are warranted for defects in material and workmanship for ten years with one year labor warranty. This limited warranty does not cover damage or equipment failure resulting from or caused by improper assembly/installation, failure to follow instructions and warnings in owner's manual, accident, misuse, abuse, unauthorized modification, or failure to provide reasonable and necessary maintenance. *TRUE Fitness shall not warrant the performance of the heart rate system on its products, as the heart rate system performance varies, based on user's physiology, age, method of use and other factors. * This limited warranty shall not apply to Software version upgrades.

Cosmetics

The elliptical cosmetic parts are warranted for defects in material and workmanship for six months with labor warranty to match the parts warranty period. This limited warranty does not cover damage or equipment failure resulting from or caused by improper assembly/ installation, failure to follow instructions and warnings in owner's manual, accident, misuse, abuse, unauthorized modification, or failure to provide reasonable and necessary maintenance. This limited warranty will apply to but may not be limited to plastic covers, shrouds, caps, badges, overlays, paint, coatings, soft step inserts and grips.

Labor

Labor is covered for a period of one year from the date of purchase unless otherwise expressed within this limited warranty as long as a TRUE authorized service provider performs the service. Service that requires over 50 miles of travel may be subject to additional charges. Reasonable and necessary maintenance guidelines can be found in the owner's manual.

Save time and register online! Activate Multiple Warranties at truefitness.com.

Claims Procedure: TRUE Limited Warranty service may be obtained by contacting the authorized TRUE dealer from whom the Product was purchased. If the dealer from whom the Product was purchased is no longer an authorized TRUE dealer, then TRUE Limited Warranty service may be obtained by contacting TRUE directly at:

TRUE Fitness, Service Department
865 Hoff Road, St. Louis, MO 63366
1-800-883-8783, (Hours of operation 8:30am - 5:00 pm CST)

The above Limited Warranty is subject to and will be in accordance with the conditions set forth below:

1. This Limited Warranty can be processed only if the Warranty Registration Form is completed on-line; or if the attached form is filled in, signed by the original purchaser and mailed to TRUE within 30 days of purchaser's receipt of this Product. The serial number must be intact on the Product for this Limited Warranty to be valid.
2. This Limited Warranty applies to the product only while the Product remains in the possession of the original purchaser and is not transferable.
3. This Limited Warranty becomes VALID ONLY if the Product is initially assembled/installed by a TRUE authorized dealer/technician (if anyone other than a TRUE authorized dealer/technician initially assembles and installs the Product, this Limited Warranty will be void unless the written authorization of TRUE is first obtained).
4. This Limited Warranty does not cover damage or equipment failure resulting from or caused by improper assembly/installation, failure to follow instructions and warnings in owner's manual, accident, misuse, abuse, unauthorized modification, or failure to provide reasonable and necessary maintenance (as referenced in the owner's manual.)
5. This Limited Warranty applies only to the cost of repair or replacement of parts and does not include labor (beyond the above warranty period), transportation, service, return and freight charges associated therewith expressly specified herein.
6. This Limited Warranty shall not apply to: Service calls to correct installation of the equipment or instruction to owners on how to use the equipment; or any labor costs incurred beyond the applicable labor warranty period.
7. This Limited Warranty is in lieu of all warranties, express or implied, and in lieu of all other obligations or liabilities on the part of TRUE, under no circumstances shall TRUE be liable by virtue of this Limited Warranty or otherwise from damage to any person or property whatsoever for any special, indirect, incidental, secondary or consequential losses, damages or expenses in connection with exercise products.

Any implied warranty is limited in duration to the time period covered by the Limited Warranty. Some states do not allow limitations on how long an implied warranty lasts, or the exclusion may not apply to you. This Limited Warranty grants you specific legal rights and you may also have other rights, which vary from state to state.

NOTE TO AUTHORIZED WARRANTY LABOR PROVIDERS:

Warranty labor reimbursement or warranty parts rights may not be transferred to, reassigned to, a third party without the express written consent of TRUE. Even jobbing out warranty labor requires TRUE's written approval.

PLEASE RETAIN THIS PORTION FOR YOUR RECORDS

Write in Your Serial Number Here:

—

Your serial number will be located on the front bottom crossbar of your ESXt, ESX Elliptical.

Example of Serial Number Sticker

The sticker contains the following information:
 S/N: *06-00003K*
 MDL: *TE83000*
 KRM07425
 120Vac ~ 50/60 Hz 15A 020409

Thank you for purchasing a TRUE product. To validate the TRUE product warranty the fast and easy way, please go on-line now to www.truefitness.com and register your product. The information you provide will never be distributed to any other individuals or agencies for any purpose. If you prefer to mail your warranty card, have the owner of the product complete the information below and return it to TRUE Fitness within 30 days from the date of equipment installation.

To mail your warranty information, please fill in the information below and mail to: Service Dept., TRUE Fitness, 865 Hoff Road, St. Louis, MO 63366 (or save postage and register online at www.truefitness.com)

Residential Warranty Registration

Model Type: Treadmill Elliptical Bike

Other _____

Date of Purchase _____

Purchased From (dealer name) _____

First Name _____

Last Name _____

Address _____

City _____ State _____ ZIP _____

Email Address _____

Phone _____

1. Where did you first learn about TRUE?

- a. Dealer b. Website
 c. Referral d. Gym/Club
 e. Current Customer f. Other _____

2. The primary user(s) is:

- a. Male b. Female
 c. Both

3. Do you currently belong to a health club?

- a. Yes b. No

4. Your age group:

- a. Under 25 b. 25-35
 c. 36-45 d. 46-55
 e. 56-65 f. 65+

5. What was the primary reason you bought a TRUE product? (Check only one)

- a. Design/Appearance b. Dealer
 c. Price d. Ease of Operation
 e. Quality of Construction f. Size
 g. Reputation h. Warranty
 i. Friend/Family Recommendation

6. Do you plan to purchase more fitness equipment in the next 6-12 months?

- Yes No

7. If you answered "yes" to question 6, what type do you plan to purchase?

- a. Treadmill b. Elliptical
 c. Stationary Bike d. Free Weights
 e. Gym c. Other _____

8. What is your annual household income? (Optional)

- a. Under \$50,000
 b. \$50,000 - \$75,000
 c. \$75,000 - \$100,000
 d. \$100,000 - \$150,000
 e. \$150,000+

9. You are a valued customer of TRUE and your suggestions allow us to continually improve your experience. Is there anything else you would like us to know? Please explain:

Write in Your Serial Number Here:

—

Your serial number will be located on the front bottom crossbar of your ESXt, ESX Elliptical.

Example of Serial Number Sticker



S/N 
 06-00003K

MOL 
 TES3000

 KRM07425

120Vac ~ 60/60 Hz 15A 020409

TSXa and TSX Warranty

Save time and register online! Activate Multiple Warranties at truefitness.com.

All TRUE® Fitness products are distributed by TRUE and are warranted to the original registered Product purchaser and the parts of the TRUE product (the “Product”) listed below, under normal use and service, shall be free of manufacturing defects in workmanship and materials only for the period of time beginning from the original date of purchase set forth below:

| Frame* | Lifetime |
|-------------------------|-----------------|
| Parts | |
| Electrical Parts | 5 Years |
| Wear Items | 5 Years |
| Cosmetics | 6 Months |
| Labor Parts | 1 Year |
| Labor Cosmetics | 6 Months |

NOTE: Warranty valid for USA and Canada only.

Frame

The frame is warranted for defects in material and workmanship for as long as the original purchaser owns the Product. The frame is warranted for labor and freight (for part shipped from TRUE) for one year from date of purchase. *This limited warranty on structural frame does not include paint or coatings.

Parts

The elliptical electrical parts and wear items are warranted for defects in material and workmanship for five years with one year labor warranty. This limited warranty does not cover damage or equipment failure resulting from or caused by improper assembly/installation, failure to follow instructions and warnings in owner’s manual, accident, misuse, abuse, unauthorized modification, or failure to provide reasonable and necessary maintenance. *TRUE Fitness shall not warrant the performance of the heart rate system on its products, as the heart rate system performance varies, based on user’s physiology, age, method of use and other factors. *This limited warranty shall not apply to Software version upgrades.

Cosmetics

The elliptical cosmetic parts are warranted for defects in material and workmanship for six months with labor warranty to match the parts warranty period. This limited warranty does not cover damage or equipment failure resulting from or caused by improper assembly/ installation, failure to follow instructions and warnings in owner’s manual, accident, misuse, abuse, unauthorized modification, or failure to provide reasonable and necessary maintenance. This limited warranty will apply to but may not be limited to plastic covers, shrouds, caps, badges, overlays, paint, coatings, soft step inserts and grips.

Labor

Labor is covered for a period of one year from the date of purchase unless otherwise expressed within this limited warranty as long as a TRUE authorized service provider performs the service. Service that requires over 50 miles of travel may be subject to additional charges. Reasonable and necessary maintenance guidelines can be found in the owner’s manual.

Claims Procedure: TRUE Limited Warranty service may be obtained by contacting the authorized TRUE dealer from whom the Product was purchased. If the dealer from whom the Product was purchased is no longer an authorized TRUE dealer, then TRUE Limited Warranty service may be obtained by contacting TRUE directly at:

TRUE Fitness, Service Department
865 Hoff Road, St. Louis, MO 63366
1-800-883-8783, (Hours of operation 8:30am - 5:00 pm CST)

The above Limited Warranty is subject to and will be in accordance with the conditions set forth below:

1. This Limited Warranty can be processed only if the Warranty Registration Form is completed on-line; or if the attached form is filled in, signed by the original purchaser and mailed to TRUE within 30 days of purchaser’s receipt of this Product. The serial number must be intact on the Product for this Limited Warranty to be valid.
2. This Limited Warranty applies to the product only while the Product remains in the possession of the original purchaser and is not transferable.
3. This Limited Warranty becomes VALID ONLY if the Product is initially assembled/installed by a TRUE authorized dealer/technician (if anyone other than a TRUE authorized dealer/technician initially assembles and installs the Product, this Limited Warranty will be void unless the written authorization of TRUE is first obtained).
4. This Limited Warranty does not cover damage or equipment failure resulting from or caused by improper assembly/installation, failure to follow instructions and warnings in owner’s manual, accident, misuse, abuse, unauthorized modification, or failure to provide reasonable and necessary maintenance (as referenced in the owner’s manual.)
5. This Limited Warranty applies only to the cost of repair or replacement of parts and does not include labor (beyond the above warranty period), transportation, service, return and freight charges associated therewith expressly specified herein.
6. This Limited Warranty shall not apply to: Service calls to correct installation of the equipment or instruction to owners on how to use the equipment; or any labor costs incurred beyond the applicable labor warranty period.
7. This Limited Warranty is in lieu of all warranties, express or implied, and in lieu of all other obligations or liabilities on the part of TRUE, under no circumstances shall TRUE be liable by virtue of this Limited Warranty or otherwise from damage to any person or property whatsoever for any special, indirect, incidental, secondary or consequential losses, damages or expenses in connection with exercise products.

Any implied warranty is limited in duration to the time period covered by the Limited Warranty. Some states do not allow limitations on how long an implied warranty lasts, or the exclusion may not apply to you. This Limited Warranty grants you specific legal rights and you may also have other rights, which vary from state to state.

Save time and register online!
 Activate Multiple Warranties at truefitness.com.

NOTE TO AUTHORIZED WARRANTY LABOR PROVIDERS:
 Warranty labor reimbursement or warranty parts rights may not be transferred to, reassigned to, a third party without the express written consent of TRUE. Even jobbing out warranty labor requires TRUE's written approval.

PLEASE RETAIN THIS PORTION FOR YOUR RECORDS

Write in Your Serial Number Here:

—

Your serial number will be located on the front bottom crossbar of your TSXa, TSX Elliptical.

Example of Serial Number Sticker

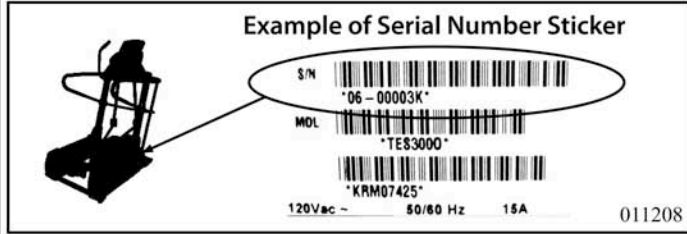

The sticker includes the following information:

- S/N: *06 - 00003K*
- MDL: *TES3000*
- *KRM07425*
- 120Vac ~ 50/60 Hz 15A
- 011208

Thank you for purchasing a TRUE product. To validate the TRUE product warranty the fast and easy way, please go on-line now to www.truefitness.com and register your product. The information you provide will never be distributed to any other individuals or agencies for any purpose. If you prefer to mail your warranty card, have the owner of the product complete the information below and return it to TRUE Fitness within 30 days from the date of equipment installation.

To mail your warranty information, please fill in the information below and mail to: Service Dept., TRUE Fitness, 865 Hoff Road, St. Louis, MO 63366 (or save postage and register online at www.truefitness.com)

Residential Warranty Registration

Model Type: Treadmill Elliptical Bike

Other _____

Date of Purchase _____

Purchased From (dealer name) _____

First Name _____

Last Name _____

Address _____

City _____ State _____ ZIP _____

Email Address _____

Phone _____

1. Where did you first learn about TRUE?

- a. Dealer b. Website
 c. Referral d. Gym/Club
 e. Current Customer f. Other _____

2. The primary user(s) is:

- a. Male b. Female
 c. Both

3. Do you currently belong to a health club?

- a. Yes b. No

4. Your age group:

- a. Under 25 b. 25-35
 c. 36-45 d. 46-55
 e. 56-65 f. 65+

5. What was the primary reason you bought a TRUE product? (Check only one)

- a. Design/Appearance b. Dealer
 c. Price d. Ease of Operation
 e. Quality of Construction f. Size
 g. Reputation h. Warranty
 i. Friend/Family Recommendation

6. Do you plan to purchase more fitness equipment in the next 6-12 months?

- Yes No

7. If you answered "yes" to question 6, what type do you plan to purchase?

- a. Treadmill b. Elliptical
 c. Stationary Bike d. Free Weights
 e. Gym c. Other _____

8. What is your annual household income? (Optional)

- a. Under \$50,000
 b. \$50,000 - \$75,000
 c. \$75,000 - \$100,000
 d. \$100,000 - \$150,000
 e. \$150,000+

9. You are a valued customer of TRUE and your suggestions allow us to continually improve your experience. Is there anything else you would like us to know? Please explain:

Write in Your Serial Number Here:

Your serial number will be located on the front bottom crossbar of your TSXa, TSX Elliptical.

Example of Serial Number Sticker



S/N 
 06-00003K

MDL 
 TES3000

 KRM07425

120Vac ~ 50/60 Hz 15A 011208



What Is TRUE World?

TRUE World is the way in which we hope to further engage our TRUE community. Whether you are a TRUE dealer, an owner of a piece of TRUE cardio equipment, or simply a fitness enthusiast, we hope you become part of TRUE World.

With the new Universal Console on TRUE cardio equipment, TRUE World is a place where YOU select the machine with the display YOU choose, tailoring each machine to fit your needs and budget. The new console choices range from classic to trendsetting.

Only in the TRUE WORLD can you find this new console design that not only provides a sleek, cohesive look, but also provides versatile display options for EVERY piece of equipment.

But that's just the beginning. Share what your TRUE World is online with us -- through our website www.truefitness.com/world or through our social media sites on Facebook and Twitter.

TRUE World is a community of users. Through that community of users we hope to continue the tradition of excellence that is TRUE. TRUE World is a place where tradition meets technology; where 29 years of continuous innovation and improvement produces ONE THING - the world's finest cardio equipment. Only TRUE users know - these rugged yet elegant machines are simply the smoothest, quietest, and most durable on the market.

TRUE WORLD is helping us prepare our premier cardio machines to meet the future.

This truly is just the beginning...



www.facebook.com/TRUE-fitness



www.twitter.com/truefitnesstech

CONTACT INFORMATION

TRUE FITNESS SERVICE DEPARTMENT
865 HOFF ROAD
ST. LOUIS, MO 63366
1.800.883.8783
HOURS OF OPERATION: 8:30 A.M. - 5:00 P.M. CST

TRUE FITNESS HOME OFFICE
865 HOFF ROAD
ST. LOUIS, MO 63366
1.800.426.6570
1.636.272.7100